

NUMERICAL OVER CURRENT & EARTH FAULT RELAY



NUMERICAL OVER CURRENT & EARTH FAULT RELAY

Prok dv's®

An ISO 9001 : 2008 Company

IDMT/DEFINITE TIME/INSTANTANEOUS LOW-SET/HIGH-SET NON-DIRECTIONAL NUMERICAL/MICROPROCESSOR BASED OVER CURRENT RELAY (OCR) WITH EARTH FAULT RELAY (EFR)- PNA SERIES IEEE DEVICES CODE-50,51,50N,51N

Prok dv's make IDMT/DEFINITE TIME/INSTANTANEOUS LOW-SET/HIGH-SET NON-DIRECTIONAL NUMERICAL/MICROPROCESSOR BASED OVER CURRENT RELAY (OCR) WITH EARTH FAULT RELAY (EFR) of KP series PNA TYPE is extensively used for selective over current and earth fault protection of radial feeders in solidly earthed, resistance earthed or impedance earthed power systems. It has wide applications in substations and industrial networks.

The IDMT/DEFINITE TIME/INSTANTANEOUS LOW-SET/HIGH-SET NON-DIRECTIONAL NUMERICAL/MICROPROCESSOR BASED OVER CURRENT RELAY (OCR) WITH EARTH FAULT RELAY (EFR) of PNA TYPE can also be used in most application where inverse time, definite time and instantaneous relays are required. The relay gives selective phase and earth fault protection in time graded systems for transformers, motors, etc. if ensures reliable protective system and clears only the faulted section.

Features

- Three phase , low-set, non - directional Over current relay with inverse definite minimum time (IDMT) or definite time characteristics
- Three phase, high-set, non-directional Over current relay with instantaneous or definite time function
- Low-set non -directional Earth fault Relay with inverse definite minimum time (IDMT) or definite time characteristics
- High-set non-directional Earth Fault Relay with instantaneous time or definite time function
- Modular Integrated Draw Out System for field adaptability and tropicalised design (MIDOS)
- Password protection
- 2 line 16 characters industrial grade LCD with back-lit module for numerical display of setting values and measured values which is user friendly
- Trips for default/previously selected curve if the fault occurs during settings of the relay
- Membrane key pad for easy operation, dust proof front panel
- Enabling /Disabling o f High-Set
- LED indications for power , pick-up, phase fault trip or Earth Fault trip f or IDMT and High-set
- RS-485 communication port with modbus protocol
- Relay test facility with relay trip & without relay trip
- Separate heavy duty output contacts provided f or time delayed phase fault with high-set and time delayed Earth Fault with high-set
- Choice o f 7 Inverse Time Characteristics Curve , for Phase Fault & Earth Fault Separately Selectable like :
 - Very Inverse
 - Normal Inverse
 - Restricted Inverse
 - Extremely Inverse
 - 3 Seconds
 - 1.3 Seconds
 - Long Time Delay

NUMERICAL OVER CURRENT & EARTH FAULT RELAY

Prok dv's®

An ISO 9001 : 2008 Company

IDMT/DEFINITE TIME/INSTANTANEOUS LOW-SET/HIGH-SET NON-DIRECTIONAL NUMERICAL/MICROPROCESSOR BASED OVER CURRENT RELAY (OCR) WITH EARTH FAULT RELAY (EFR)- PNA SERIES IEEE DEVICES CODE-50,51,50N,51N

- Definite time curve for both Phase & Earth along with optional user defined curve.
- Low AC burden
- Reliable auxiliary supply of wide range input of 18-85 or 85-275 volts AC or DC
- Non-Volatile memory for data retention and retrieval in the event of power failure
- Unique combination of 50/51/50N/51N in a single gadget
- Consistent repeat accuracy
- High Drop-off/Pick-up ratio
- Poly carbonate front cover with external reset switch

Application

The IDMT/DEFINITE TIME/INSTANTANEOUS LOW-SET/HIGH-SET NON-DIRECTIONAL NUMERICAL/MICROPROCESSOR BASED OVER CURRENT RELAY (OCR) WITH EARTH FAULT RELAY (EFR) of KP Series PNA TYPE is extensively used for selective short circuit and earth fault protection of radial feeders in solidly earthed, resistance earthed or impedance earthed power systems. It has wide applications in substations & industrial networks.

The IDMT/DEFINITE TIME/INSTANTANEOUS LOW-SET/HIGH-SET NON-DIRECTIONAL NUMERICAL/MICROPROCESSOR BASED OVER CURRENT RELAY (OCR) WITH EARTH FAULT RELAY (EFR) of PNA TYPE can also be used in most application where inverse time, definite time and instantaneous relays are required. The relay gives selective phase and earth fault protection in time graded systems for transformers, motor etc. It ensures reliable protective system and clears only the faulted section.

Description

Prok dv's make PNA TYPE IDMT/DEFINITE TIME/INSTANTANEOUS LOW-SET/HIGH-SET NON-DIRECTIONAL NUMERICAL/MICROPROCESSOR BASED OVER CURRENT RELAY (OCR) WITH EARTH FAULT RELAY (EFR) or independent over current Relay (OCR) or earth fault relay (EFR). This is intended for protection application in medium voltage networks. These networks may have isolated or resistance impedance earthed or solidly earthed neutral points. Definite time over current relays are both suited for isolated systems and for use as back up to differential relays and distance relays. Inverse time relays (over current relays with various inverse times - current characteristics) are advantageous for interconnected systems and solidly grounded systems. Another tool for reducing the tripping time for faults near the source is to use the added instantaneous (high set) feature in the numeric relay .if the fault occurs during the setting of relay ,the relay shall operate / trip for the previously selected / default settings.

Relay has modbus protocol with RS 485 port with baud rate 9600bps. Another model is established for special applications with baud rate 115kbps. Relay records 99 faults with date and time. Relay rating (In) is field selectable- either 1A/5A. The output relays are configurable. Configurable options for enabling & disabling of high-set in both Phase & earth.

PNA TYPE IDMT/DEFINITE TIME/INSTANTANEOUS LOW-SET/HIGH-SET DIRECTIONAL NUMERICAL/MICROPROCESSOR BASED OVER CURRENT RELAY (OCR) WITH EARTH FAULT RELAY (EFR) receives the input current signals (phase current and neutral current) via four input current transformers. These signals are galvanically de-coupled, suitably filtered and fed to the micro-controller, for amplitude calculation and further logical processing.

NUMERICAL OVER CURRENT & EARTH FAULT RELAY

Prok dv's [®]

An ISO 9001 : 2008 Company

IDMT/DEFINITE TIME/INSTANTANEOUS LOW-SET/HIGH-SET NON-DIRECTIONAL NUMERICAL/MICROPROCESSOR BASED OVER CURRENT RELAY (OCR) WITH EARTH FAULT RELAY (EFR)- PNA SERIES IEEE DEVICES CODE-50,51,50N,51N

The micro-controller continuously monitors the magnitude of the phase current and the neutral current . whenever the phase current or the earth current magnitude exceeds the present value corresponding line / earth element will pick up and relay will trip after time interval calculated by the selected IDMT curves. Whenever the fault level exceeds the selected high set range, the relay will trip for high set, ignoring the selected IDMT curves. The timer logic is processed and after comparison with set time schedules, tripping signals are issued accordingly. There are two output relays , each output relay has two change over contacts either for alarm or tripping. The output relays are programmable. The relay rating (In) is field selectable either 1A or 5A. The relay has RS 485 com port which can be used with modbus protocol for communication purposes.

The auxiliary supply for the numeric relay is provided by a switch mode power supply unit with input voltage either AC or DC with a wide operating voltage from 21-130 volts or 85-275 volts. And in case of AC, the power supply is designed operate from 45HZ - 65HZ.

IDMT/DEFINITE TIME/INSTANTANEOUS LOW-SET/HIGH-SET NON-DIRECTIONAL NUMERICAL/MICROPROCESSOR BASED OVER CURRENT RELAY (OCR) WITH EARTH FAULT RELAY (EFR)- PNA SERIES IEEE DEVICES CODE-50,51,50N,51N

Specification

PARAMETER	TYPE : PNA – Series IDMT/DEFINITE TIME/INSTANTANEOUS LOW-SET/HIGH-SET NON-DIRECTIONAL NUMERICAL/MICROPROCESSOR BASED OVER CURRENT RELAY (OCR) WITH EARTH FAULT RELAY (EFR)- PNA SERIES
ACCURACY OF OPERATING TIME ➤ FOR IDMT ➤ DEFINITE TIME ➤ INSTANTANEOUS	±5% ±3% Less than 2 Cycles
RELAY RATED CURRENT (IN)	1A or 5A user selectable.
FREQUENCY	50Hz or 60Hz.
AUXILIARY VOLTAGE RANGE	85V - 275V AC/DC, 21 -130V DC
PICK-UP	103%
DROP-OFF	97%
AC BURDEN	< 0.4VA for 5A < 0.2VA for 1A @ unity pf.
DC BURDEN	< 5W during non operated condition < 7W during operated condition
DIMENSIONS	151 x181x195 mm (WxHxD)
MOUNTING	Flush
PANEL CUT - OUT	151 x 157 mm + 0.1mm
CONTACT RATING	AC: 250 V @ 30 AMP DC: 24 V @ 30 AMPS, 2 C/O or 3 C/O
OPERATING TEMPERATURE	- 5? to +55? C

NUMERICAL OVER CURRENT & EARTH FAULT RELAY

IDMT/DEFINITE TIME/INSTANTANEOUS LOW-SET/HIGH-SET NON-DIRECTIONAL NUMERICAL/MICROPROCESSOR BASED OVER CURRENT RELAY (OCR) WITH EARTH FAULT RELAY (EFR)- PNA SERIES IEEE DEVICES CODE-50,51,50N,51N

Relay Plug Setting Ranges

Low- Set Range (IDMT)

Low Set PS	Setting Range	Step	TMS Range	TMS Step
Phase Low-Set PS	(0.1 - 2.5) In - 5A (0.5-2.5) In-1A	0.01	(0.10-1.60)	0.01
Earth Low-Set PS	(0.1-0.8) In	0.01	(0.10-1.60)	0.01

High -Set Range

High Set Current	Setting Range	Step	Time Range	Time Step
Phase High-Set	(2-30) In	0.1	(0.0-1.60)	0.1
Earth High-Set	(0.5-16) In	0.1	(0.0-1.60)	0.1

Definite Time Settings Ranges

Low- Set PS	Setting Range	Step	TMS Range	TMS Step
Phase Low-Set PS	(0.1- 2.5) In- 5A (0.5-2.5) In-1A	0.01	(1-160)	0.1
Earth Low-Set PS	(0.1-0.8) In	0.01	(1-160)	0.1

Output Relay Configuration

Phase Low-Set	Relay1 or Relay2 can be assigned
Earth Low-Set	Relay1 or Relay2 can be assigned
Phase High-Set	Relay1 or Relay2 can be assigned
Earth High-Set	Relay1 or Relay2 can be assigned

Auto Re-closure:

Min - Minutes	
AR Shot 1	0.5 Min(0.0-10) Step_ 0.5
AR Shot 2	0.5 Min(0.0-10) Step_ 0.5
AR Shot 3	0.5 Min(0.0-10) Step_ 0.5
AR Shot 4	0.5 Min(0.0-10) Step_ 0.5

Mod Bus Protocol

Modbus Slave ID	1(1-31)
BAUD RATE	9600bps
	4800bps
	2400bps
	1200bps
	115.2kbps
	38.4kbps
	19.2kbps

NUMERICAL OVER CURRENT & EARTH FAULT RELAY

IDMT/DEFINITE TIME/INSTANTANEOUS LOW-SET/HIGH-SET NON-DIRECTIONAL NUMERICAL/MICROPROCESSOR BASED OVER CURRENT RELAY (OCR) WITH EARTH FAULT RELAY (EFR)- PNA SERIES IEEE DEVICES CODE-50,51,50N,51N

WIRING DIAGRAM OF IDMT/DEFINITE TIME/INSTANTANEOUS LOW-SET/HIGH-SET NON-DIRECTIONAL NUMERICAL/MICROPROCESSOR BASED OVER CURRENT RELAY (OCR) WITH EARTH FAULT RELAY (EFR)- PNA - 442

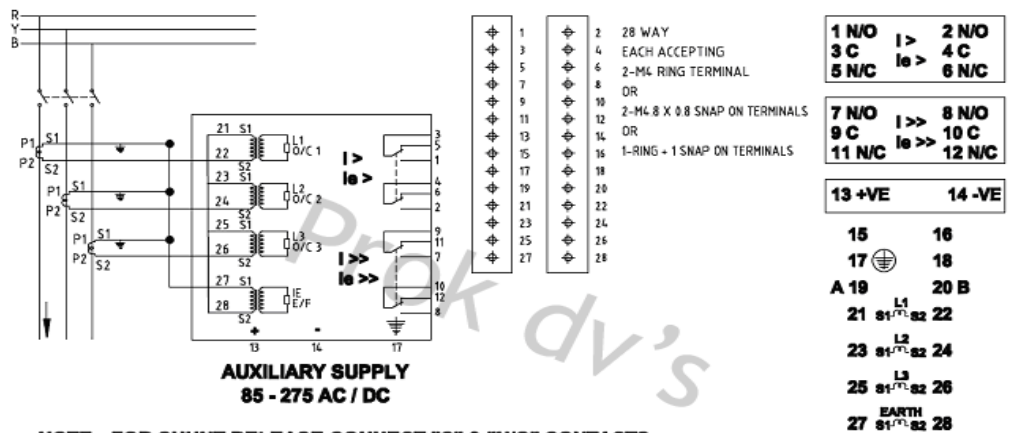

**NOTE: FOR SHUNT RELEASE CONNECT "C" & "N/O" CONTACTS
FOR UV RELEASE OR CONTACTOR COIL CONNECT "C" & "N/C"
CONTACTS SHOWING IN HEALTHY CONDITION
A & B - COMMUNICATION PORT - RS485**

MECHANICAL DIMENSION OF IDMT/DEFINITE TIME/INSTANTANEOUS LOW-SET/HIGH-SET DIRECTIONAL NUMERICAL/MICROPROCESSOR BASED OVER CURRENT RELAY (OCR) WITH EARTH FAULT RELAY (EFR)- PNA - 442PNA - 442

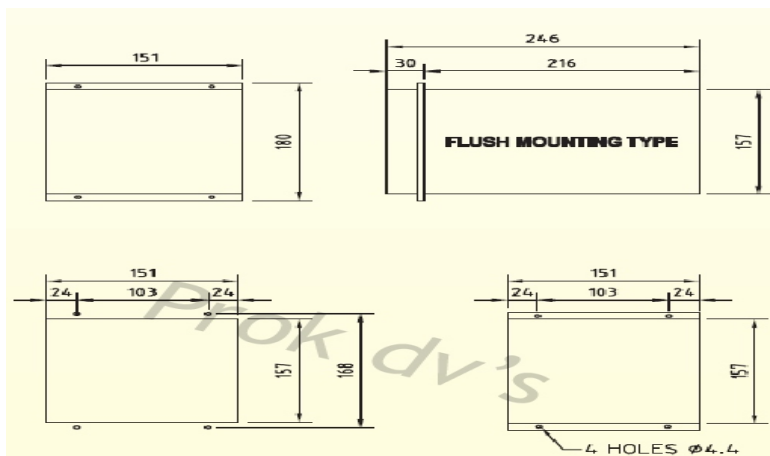

**NOTE: ALL DIMENSIONS ARE IN MM
TOLERANCE:- ± 0.1MM**

NUMERICAL OVER CURRENT & EARTH FAULT RELAY

Prok dv's®

An ISO 9001 : 2008 Company

IDMT/DEFINITE TIME/INSTANTANEOUS LOW-SET/HIGH-SET NON-DIRECTIONAL NUMERICAL/MICROPROCESSOR BASED OVER CURRENT RELAY (OCR) WITH EARTH FAULT RELAY (EFR)- PNA SERIES IEEE DEVICES CODE-50,51,50N,51N



ISO 9001-2008

Prok Devices Private Limited
SIMHADRI ,No.2930, 14 th Cross,
Banashankari II nd Stage, Off K.R. Road,
Bengaluru-560070
Karnataka,India

Tel: +91 80 43487777/26760718/26761719

Fax: +91 80 26761720

For Marketing Information & Assistance

enquiry@prokdvs.com

marketing@prokdvs.com

For Product Information & Technical Details

info@prokdvs.com

For Service Information

service@prokdvs.com